



ES4.5-4

SPECIFICATIONS

Nominal Voltage (V) 4V

Nominal Capacity

20 hour rate (0.225A to 3.5V)	4.5Ah
10 hour rate (0.42A to 3.5V)	4.2Ah
5 hour rate (0.765A to 3.4V)	3.825Ah
1C (4.5A to 3.2V)	2.55Ah
3C (13.5A to 3.2V)	1.8Ah

Weight Approx. 1.06Lbs. (0.48kg)

Internal Resistance (at 1KHz) 22 mΩ

Maximum Discharge Current for 5 seconds : 45A

Operating Temperature Range

Charge	0°C (32°F) to 50°C (122°F)
Discharge	-20°C (68°F) to 60°C (140°F)
Storage	-20°C (68°F) to 60°C (140°F)

Charging Methods at 25°C (77°F)

Cycle Use : Charging Voltage 4.8 to 5.0V
Coefficient -5.0mv / °C / cell
Maximum Charging Current : 1.35A

Standby Use : Float Charging Voltage 4.5 to 4.6V
Coefficient -3.0mv / °C / cell

Case Material : ABS
(Option : UL94 HB Flame Retardant Case Material)

Terminal : F2

Maintenance-Free Rechargeable Sealed Lead-Acid Battery



DIMENSIONS

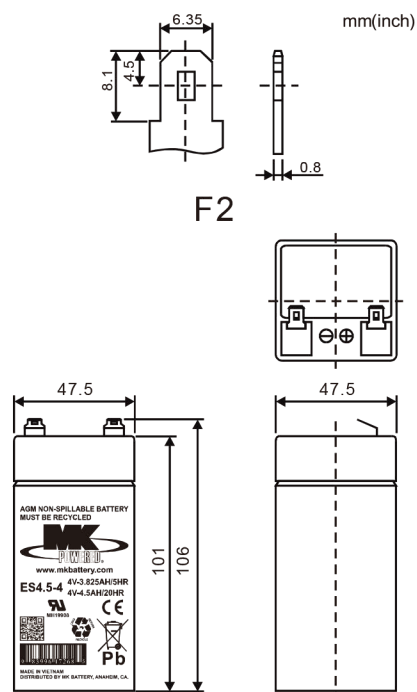

Authorized Agent:



香港可再生能源有限公司
Hong Kong Renewable Energy Co. Ltd.

地址: 香港九龍旺角彌敦道610號荷李活商業中心18樓

電話: 2960 0193

郵箱: cml@live.hk

傳真: 2960 0553

網址: <http://www.hkre.com.hk/>